

A close-up, high-angle photograph of an Autolite spark plug. The plug is oriented vertically, with its hexagonal base at the top and its threaded body extending downwards. The top of the plug is partially obscured by a horizontal orange and black gradient bar. The main body of the plug is silver with a black band around the hexagonal base. The word "Autolite" is printed in black on this band. The lower portion of the plug is threaded and has a bright, starburst light emanating from its tip, suggesting it is firing. The background is dark, with a textured, diamond-plate pattern visible in the upper portion of the image.

Autolite®

SPARK PLUG

TECHNICAL TRAINING MANUAL



<i>Autolite History</i>	3
<i>Basic Engine Operation (4-stroke/2-stroke)</i>	4
<i>Requirements for Engine Operation</i>	6
<i>Ignition System Basics</i>	7
<i>Types of Ignition Systems</i>	8
<i>How Spark is Generated</i>	13
<i>Ignition System Advance/Retard</i>	14
<i>The Role of the Spark Plug</i>	15
<i>Spark Plug Heat Ranges</i>	18
<i>Changes in Voltage Requirements</i>	19
<i>Anatomy of a Spark Plug</i>	22
<i>Types of Spark Plugs</i>	23
<i>How to Read Autolite Spark Plug Numbers</i>	26
<i>Selling the Right Spark Plug</i>	27
<i>Installation Guide</i>	28
<i>Service Life & Misfiring</i>	31
<i>Troubleshooting</i>	33
<i>Frequently Asked Questions</i>	37
<i>Autolite Sponsored Racing</i>	39

AUTOLITE® BRAND HERITAGE

Founded in 1911 to produce horse-drawn carriage lamps, the Electric Autolite Company was a thriving automotive parts manufacturer by the 1930s. The company's signature product was developed in 1935 when a new laboratory was equipped and staffed specifically to engineer the first Autolite spark plug. Success came quickly, and soon Autolite was supplying spark plugs and ignition components to original equipment manufacturers such as Chrysler, Studebaker, Packard and Willys.

- **1936:** First Autolite spark plug produced in Fostoria, Ohio
- **1948:** The Autolite Resistor spark plug introduced
- **1956:** Autolite produces first Power Tip spark plug
- **1976:** Autolite produces first Suppressor spark plug
- **1987:** Autolite produces first Platinum spark plug
- **2003:** Autolite produces the first High Thread (HT) spark plug for Ford Triton engines
- **2005:** Autolite produces first 0.6 mm fine wire XP Xtreme Performance® spark plug
- **2007:** Autolite produces its 10 billionth spark plug.
- **2007:** Autolite introduces coil-on-plug insulator boots, and Xtreme Sport® and Xtreme Start™ premium small-engine spark plugs

Today, the Autolite brand continues to grow, providing the automotive aftermarket and OEMs with the high-quality ignition products, including spark plugs, ignition wire sets and coil-on-plug boots. State-of-the-art process control and automated inspection helps ensure that quality Autolite products meet rigorous internal and customer demands.

Autolite is a unit of the UCI/Fram Group, which also manufactures and markets:

- FRAM® oil, air, transmission and fuel filters
- Prestone® antifreeze/coolant and car care products
- Airtex® Fuel Pumps
- Wells Vehicle Electronics
- ASC Water Pumps



BASIC ENGINE OPERATION

There are two basic types of gasoline-powered piston engines: Four-stroke and two-stroke.

FOUR-STROKE ENGINES

This most common type of engine, found in cars, trucks and many motorcycles, goes through four “strokes” or “cycles” of operation:

1. Intake
2. Compression
3. Power
4. Exhaust

1. Intake

As the piston moves downward, the intake valve opens, and a mixture of air and gasoline vapor (air/fuel) is sucked into the cylinder.

2. Compression

As the piston reaches its lowest point (Bottom Dead Center) and then moves back upward, the intake valve closes, and the air/fuel mixture is compressed.

3. Power

When the piston is near the top of its travel (Top Dead Center), the spark plug “fires,” which ignites the air/fuel mixture. The pressure from the burning fuel forces the piston downward.

4. Exhaust

As the piston then moves back upward, the exhaust valve opens, and the burnt gases are pushed out of the cylinder. The cycles then repeat.

Four-Stroke Engine Advantages: Durable and efficient. Can be tuned for a combination of high power, low fuel consumption and low emissions.

Four-Stroke Engine Disadvantages: Requires complex control systems to produce the optimal combination of power, fuel consumption and emissions.

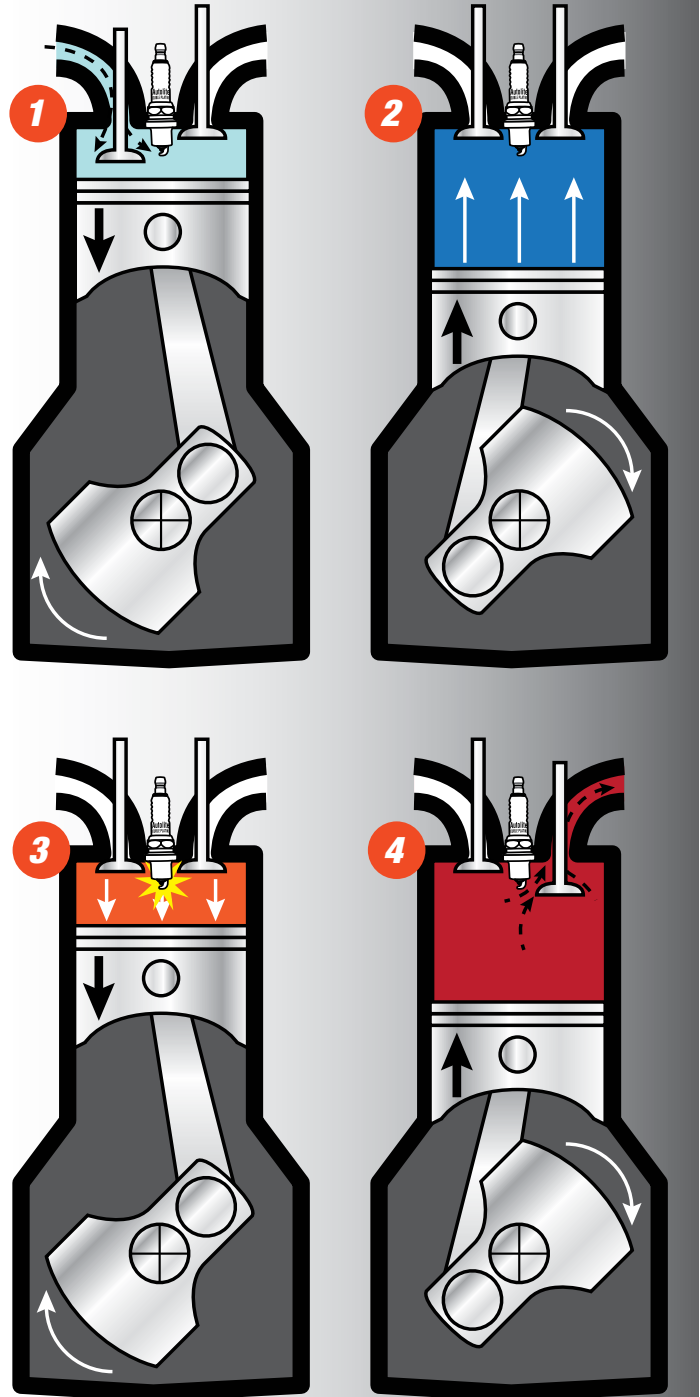

BASIC ENGINE OPERATION

TWO-STROKE ENGINES

Two-stroke engines are found in many motorcycles as well as devices such as chain saws and weed cutters. This type of engine only has two strokes or cycles of operation:

1. Intake/Compression
2. Power/Exhaust

1. Intake/Compression

When the piston is at the bottom of its downward travel (Bottom Dead Center), the intake port is uncovered. Air and a mixture of gasoline and oil flow into the cylinder. As the piston moves upward, this mixture is compressed.

2. Power/Exhaust

When the piston is near the top of its travel (Top Dead Center), the spark plug “fires,” which ignites the mixture. The pressure from the burning fuel forces the piston downward. As the piston moves downward, it uncovers the exhaust port, which allows burnt gases to escape.

Two-Stroke Engine Advantages: Powerful, light in weight and simple in construction. Two-stroke engines produce power once every revolution versus four-stroke engines, which produce power every other revolution.

Two-Stroke Engine Disadvantages: Requires a mixture of oil and gasoline to operate. Lack of a dedicated lubrication system means two-stroke engines do not last as long as four-stroke engines. Difficult to control exhaust emissions.

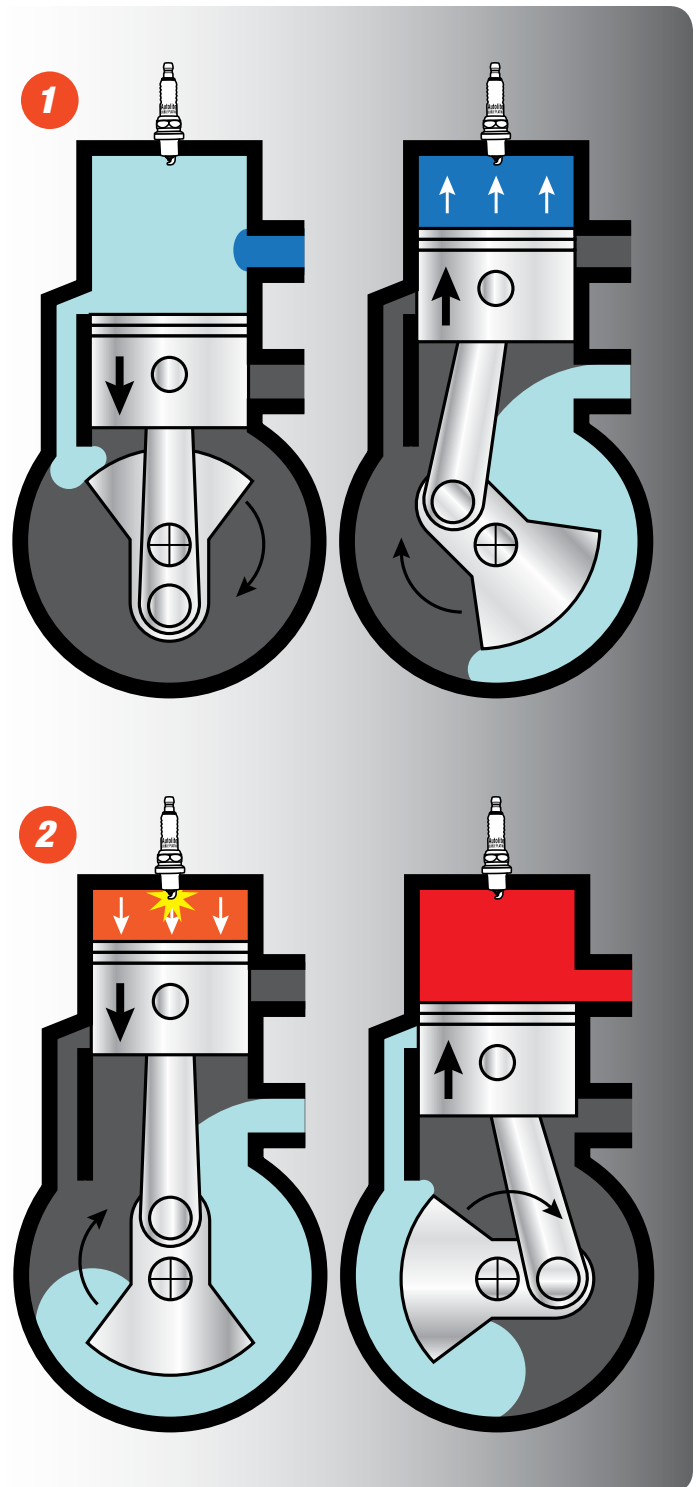

REQUIREMENTS FOR ENGINE OPERATION

While there are many things that can affect engine performance, these are the most basic requirements for a gasoline engine to operate:

1. The right air/fuel mixture
2. Good compression
3. High-voltage ignition

1. Air/Fuel Mixture

Gasoline vapor must be mixed with air in a relatively precise ratio in order for an engine to run properly. An air/fuel ratio that is too “rich” – too much gasoline – may ignite, but will create excess exhaust emissions and will shorten the life of many engine components. An air/fuel ratio that is too “lean” – too little gasoline – may not ignite, or may ignite but not create enough power.

The ideal air/fuel ratio for complete combustion and good power is called a stoichiometric ratio – about 14.7 parts of air to 1 part gasoline. During the course of an engine’s operation, however, the air/fuel ratio will vary:

- A higher ratio of fuel to air will be required during acceleration or heavy demands on the engine (called “high-load” situations)
- A lower ratio of fuel to air can be used during deceleration or “light-load” situations

Modern engines with computer-controlled fuel injection systems can vary the air/fuel ratio very precisely for a wide range of driving conditions in order to achieve strong performance, low fuel consumption and low emissions.

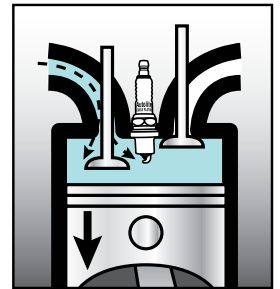

2. Compression

Compressing the air/fuel mixture into a smaller, denser volume generates more power when the mixture is ignited. An engine’s compression ratio is measured by comparing the maximum volume of the cylinder to the minimum volume of the cylinder as the piston moves up and down:

Compression ratio = Cylinder volume with the piston at its lowest downward position (Bottom Dead Center) divided by cylinder volume with the piston at its highest upward position (Top Dead Center)

The compression ratio on passenger-car engines can be as low as 8.0:1 or as high as 12.0:1. The higher the compression ratio, the greater the combustion pressure, which will produce more power. However, higher compression ratios require higher-octane gasoline, and often need more complex fuel and ignition system controls to prevent damaging engine knock.

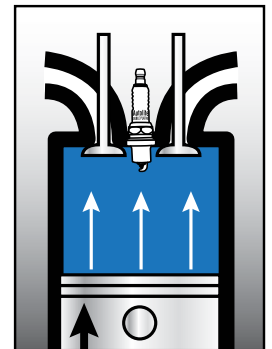

3. High-Voltage Ignition

Spark is essential to an engine’s operation. The electrical spark that is generated across the gap of a spark plug’s electrodes is what ignites the air/fuel mixture. This explosive combustion of gasoline vapor forces the piston downward, which turns the crankshaft, generating power that ultimately turns the wheels.

In a modern engine, thousands of volts of electricity are required for complete combustion. Equally as important as the strength of the spark is its timing – ignition should occur near each piston’s Top Dead Center position. This ignition timing is not constant, however, and must vary with engine speed and load. More information on this subject will be provided later in this manual.

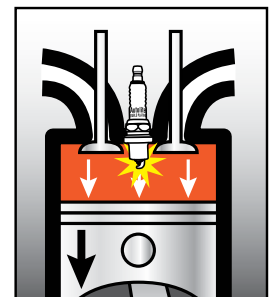

IGNITION SYSTEM BASICS

All ignition systems comprise the following components or functions:

- 1. A battery** to supply the initial voltage (usually 12 volts) to the coil
- 2. An ignition coil** to generate the much higher voltage that is needed to ignite the air/fuel mixture. In simple terms, this is an electrical transformer with two windings on a magnetic core.
- 3. A distributor** (or an electronic device that provides the same services), which handles two tasks: Triggering the coil to release its electrical current, and distributing this strong electrical current from the coil to each spark plug at the appropriate time
- 4. A spark plug** for each cylinder, which applies the electrical current from the coil to the gap between its electrodes in order to generate a strong enough spark to ignite the air/fuel mixture in the cylinder

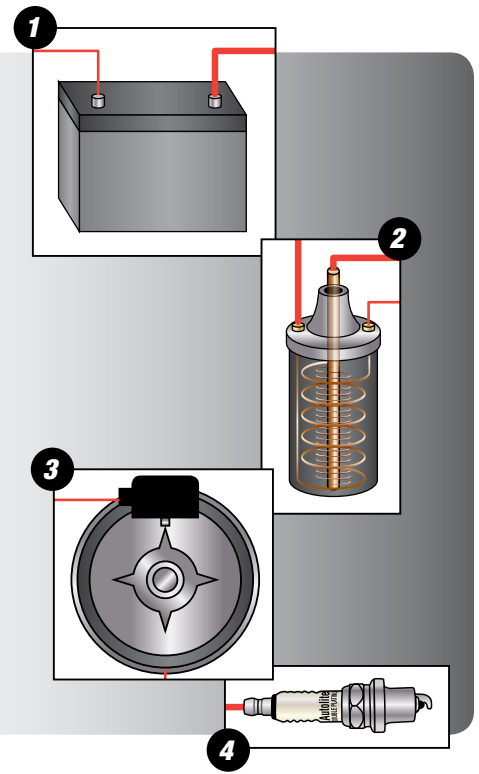

Some types of ignition systems have additional hardware. Some have multiple ignition coils. The most sophisticated ignition systems delete the distributor entirely, and instead rely on signals from an Engine Control Unit (ECU) to determine ignition timing.

In every case, however, the electrical energy that starts as very low voltage is increased dramatically by the coil to create the spark that arcs across the gap that ignites the air/fuel mixture.

TYPES OF IGNITION SYSTEMS

There are five different types of ignition systems used in cars, trucks and motorcycles:

1. Conventional Breaker-Point Ignition
2. High Energy (Electronic) Ignition
3. Distributorless (Waste Spark) Ignition
4. Coil On Plug (Direct) Ignition
5. Capacitor Discharge Ignition (CDI)

Conventional Breaker-Point Ignition System

This is the oldest type of ignition system, which has been used since the early days of the automobile. It is completely mechanical and electrical, with no electronic controls. The most complex mechanism in this system is the distributor, driven off the engine's camshaft, which:

- Uses breaker points to trigger the ignition coil to generate a pulse of high-voltage energy
- Uses a cap and spinning rotor to distribute high voltage to each spark plug at the appropriate time

Advantages: Relatively easy to diagnose and repair. A traditional, well-sorted system.

Disadvantages: Contains many moving parts. Requires frequent maintenance. Breaker point deterioration cannot provide maximum spark energy for every spark event throughout the life of the engine (frequent misfires are possible, increasing emissions). Ignition timing cannot be precisely controlled.

Typical Spark Plug Used: Autolite® Copper Core

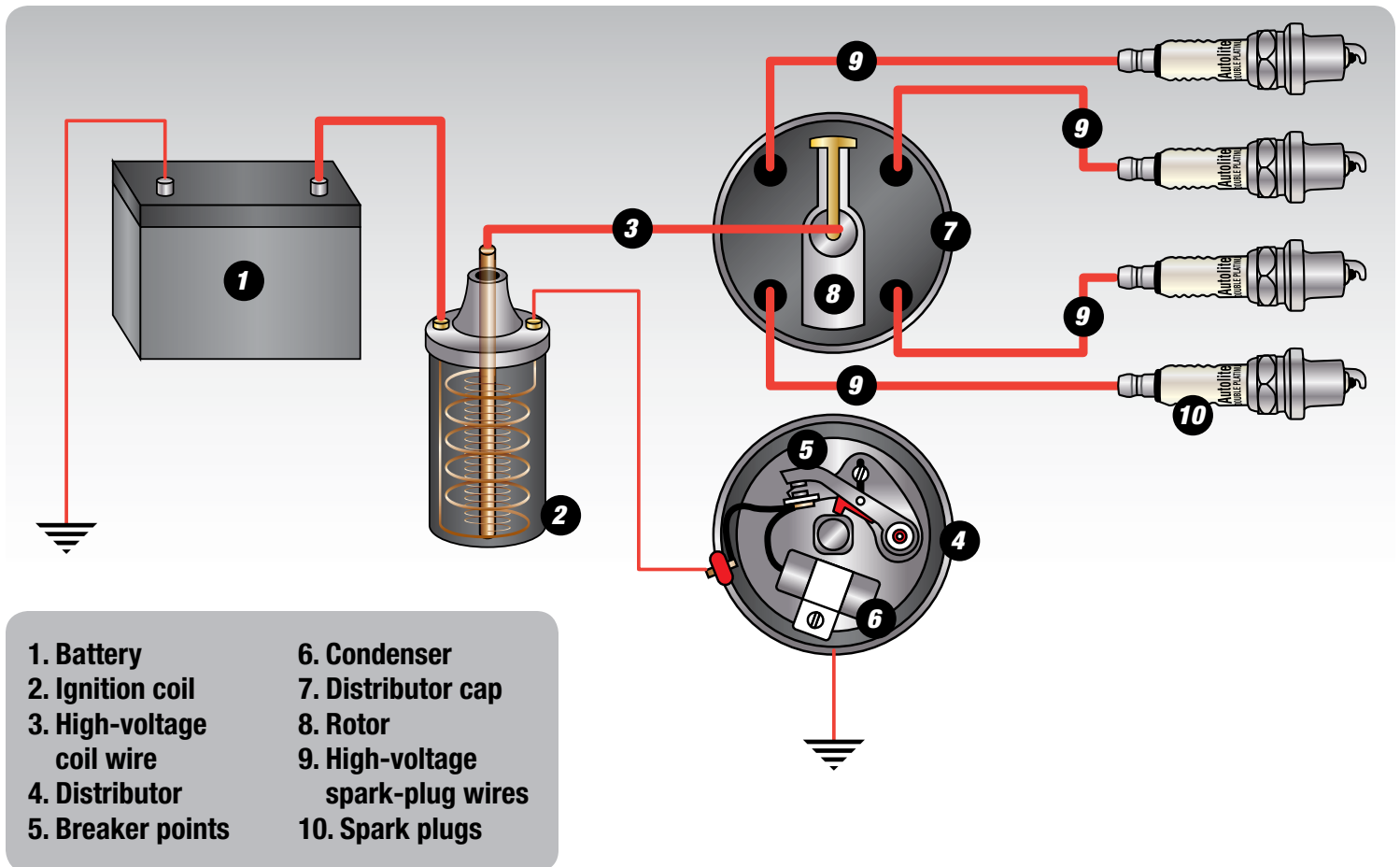

TYPES OF IGNITION SYSTEMS

High Energy (Electronic) Ignition System

This system replaces the breaker points and condenser with a transistorized switch within an ignition module that handles the same task – triggering the ignition coil to generate high-voltage current. The distributor cap and rotor still perform the same job of distributing current to the spark plugs.

Advantages: Fewer moving parts than a breaker-point ignition system. Relatively easy to diagnose and repair. Can consistently provide high voltage for every spark throughout the life of the engine (minimal misfires).

Disadvantages: Still relies on a conventional distributor, which eventually wears and requires replacement. Ignition timing cannot be as precisely controlled as with more sophisticated systems.

Typical Spark Plug Used: Autolite® Copper Core or Autolite® Platinum

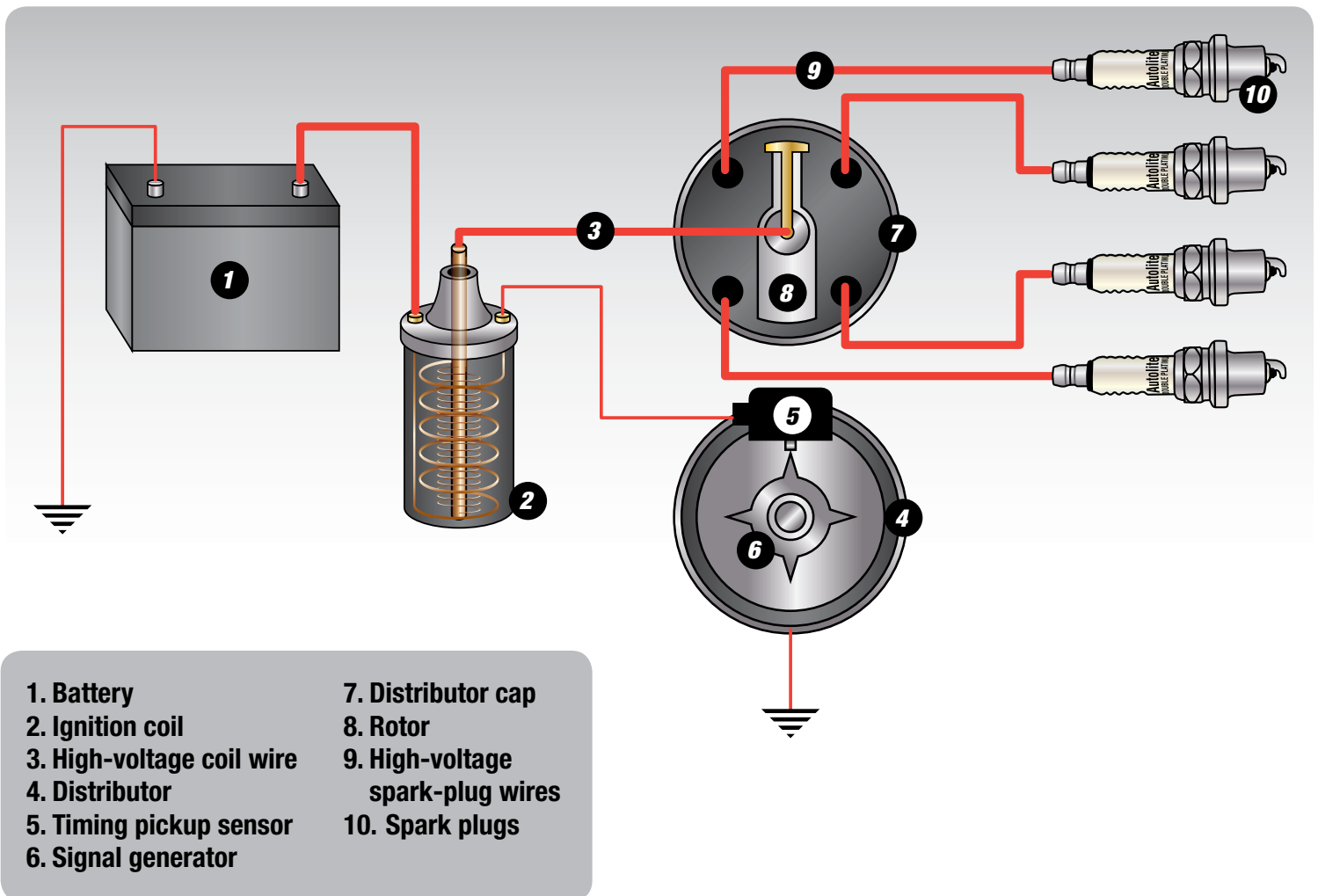

TYPES OF IGNITION SYSTEMS

Distributorless (Waste Spark) Ignition System

This system eliminates the distributor entirely, and uses multiple ignition coils – one for each pair of cylinders. Using engine sensors to determine crankshaft position and sometimes camshaft position, an Electronic Control Unit triggers the appropriate ignition coil and directs the distribution of electrical current to the spark plugs.

The trick behind this system is the use of “waste spark” for one of the paired cylinders. This setup pairs two pistons that will be at Top Dead Center at the same time – one will be at the end of its compression stroke, and the other will be at the end of its exhaust stroke. Each of the spark plugs in these cylinders will fire at the same time using the high voltage from one coil. The piston at the end of its compression stroke will generate power from the ignition of the air/fuel mixture. Igniting the spark plug for the piston at the end of its exhaust stroke will not perform any function – that is the waste spark cylinder.

Advantages: No moving parts. Lower maintenance costs. Can be designed to generate high voltage. Ignition timing can be precisely controlled for low emissions.

Disadvantages: More difficult to diagnose and more expensive than a traditional system. Still requires high-voltage wires from the coils to the spark plugs, like a traditional system.

Typical Spark Plug Used: Autolite® Double Platinum or Autolite XP Xtreme Performance®

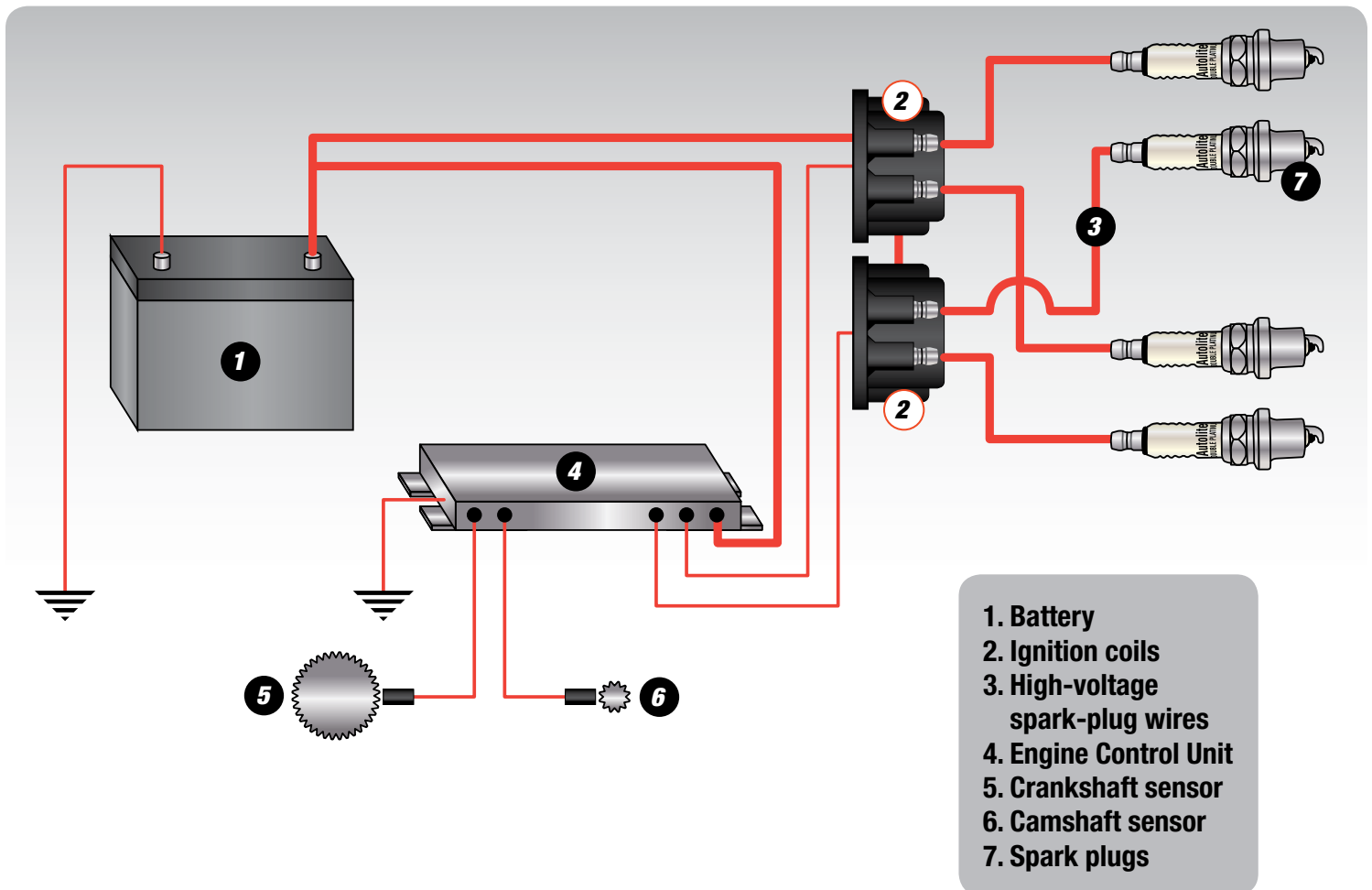

TYPES OF IGNITION SYSTEMS

Coil On Plug (Direct) Ignition

This most sophisticated of all ignition systems places an ignition coil directly on top of each spark plug. All of the ignition timing is handled by the Engine Control Unit, based on input from various sensors. Because each spark plug has its own dedicated coil, high-voltage spark-plug wires are completely eliminated.

Advantages: No moving parts. Lower maintenance costs. Can be designed to generate high voltage. Ignition timing can be precisely controlled for low emissions. Ideal for high-rpm engines.

Disadvantages: More difficult to diagnose and more expensive to repair than a traditional system.

Typical Spark Plug Used: Autolite XP Xtreme Performance® or Autolite® Platinum

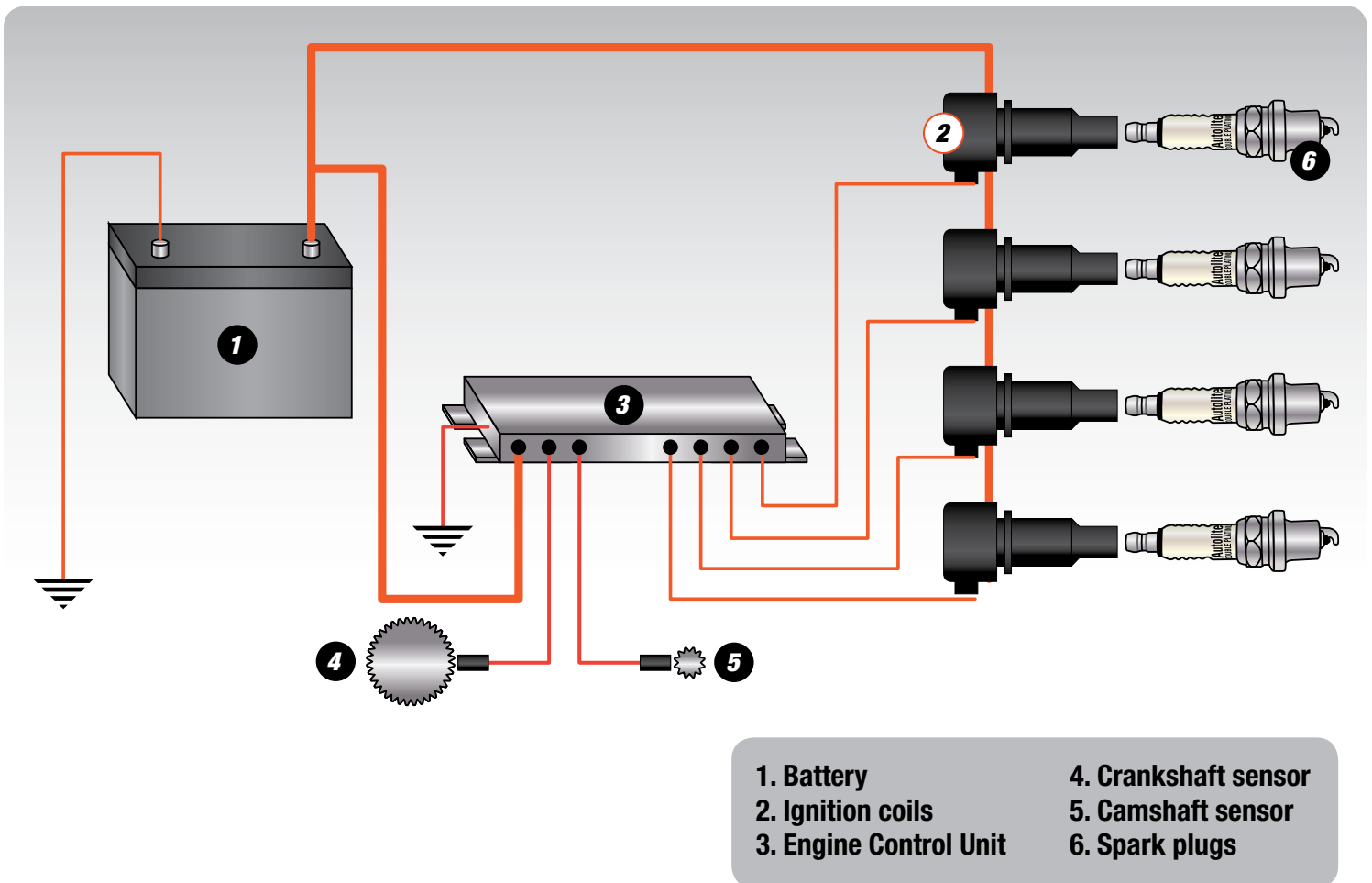

TYPES OF IGNITION SYSTEMS

Capacitor Discharge Ignition (CDI) System For Small Engines

CDI systems are typically used on small engines – lawn mowers, chain saws, outboard boat motors or motorcycles, including two-stroke and four-stroke engines. Configurations vary widely, and may include a battery and alternator, or a magneto and no battery. The basic system described below uses the engine's flywheel as both a magneto, to generate the initial voltage, and a triggering device, like the rotor of a distributor.

- Permanent magnets embedded in the flywheel rotate around stationary source coils, creating the initial voltage
- Voltage flows to a capacitor, which builds the electrical charge to about 250+ volts
- A triggering device, mounted near the flywheel, signals the CDI control unit's transistorized switching device (also known as a thyristor) to stop charging the capacitor
- At that point, the capacitor discharges its voltage into the coil primary winding. The coil secondary winding steps up the voltage so it can jump the gap at the spark plug

Advantages: Relatively easy to diagnose and repair. Short charging times and short spark duration are suitable for high-speed operation

Disadvantages: Spark duration may be too short for reliable ignition with leaner air/fuel mixtures. Can be hard to start. Generally not suitable for automotive applications.

Typical Spark Plug Used: Autolite® Small Engine, Autolite® Xtreme Start™ or Autolite® Xtreme Sport®, depending upon application.

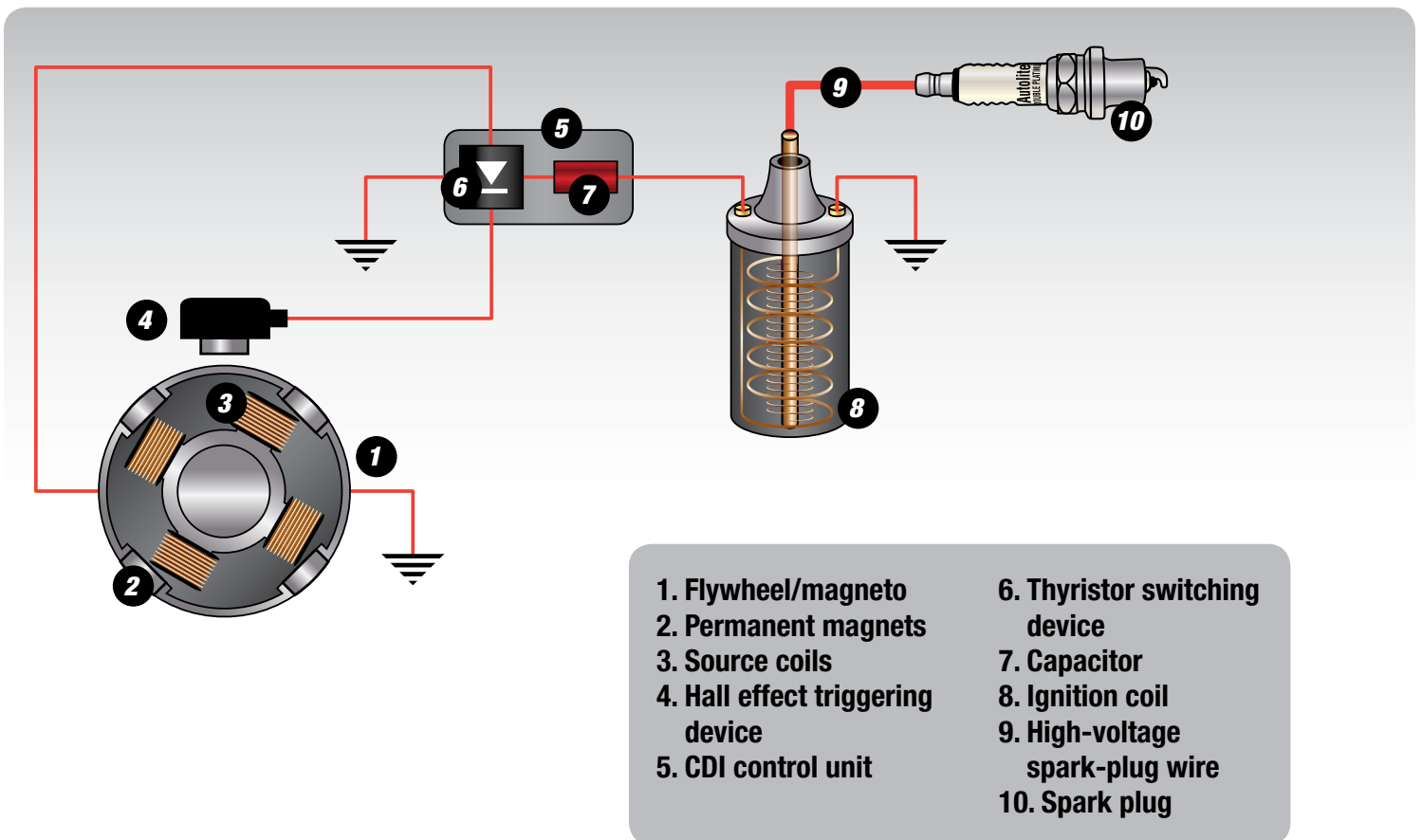

HOW A HIGH-VOLTAGE SPARK IS GENERATED

While ignition system configurations vary, some things are constant for all of them: The ignition coil powers the system, and the spark plug delivers the spark that starts combustion.

The Ignition Coil

The coil takes battery voltage and transforms it to a high enough level to jump the gap of the spark plug to ignite the air/fuel mixture inside the combustion chamber under a wide range of operating conditions.

- A coil is basically a small electrical transformer
- Modern coils can generate between 15,000 and 40,000 volts

What Happens During Ignition

When the air/fuel mixture in the cylinder is ignited, there's a spike in both temperature and pressure. Basically, the mixture is converted into heat and burnt gases that generate high pressure inside the combustion chamber. This pressure forces the piston downward, providing torque to the crankshaft.

The timing of the ignition of this air/fuel mixture is critical. The spark generated when the high voltage sent to the center electrode arcs across the gap to the ground strap (also called a side electrode) is very brief – only about 1/1000 of a second. And there is a very slight delay between the time when the spark plug fires and the time when the air/fuel mixture is fully ignited – when pressure in the combustion chamber reaches its maximum.

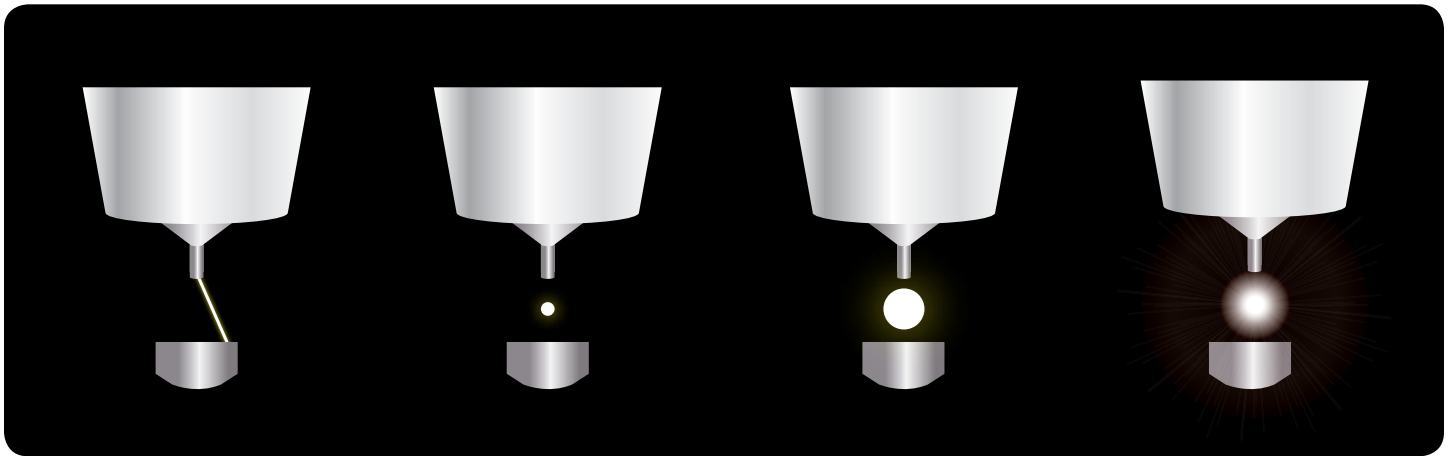

This is because the spark plug ignites only the air/fuel mixture in the gap between electrodes, generating a flame kernel. This flame kernel quickly creates a flame front that expands outward, igniting the rest of the air/fuel mixture.

- If the spark plug fires too soon, the pressure will try to push down on the piston while it is still moving upward on the compression stroke
- If the spark plug fires too late, the air/fuel mixture will not be compressed properly and the weak combustion won't generate as much power

You would logically assume that ignition should occur when the piston is at Top Dead Center (TDC) – its highest position. In reality, the optimal start of ignition is before TDC because of this slight delay between actual spark and maximum cylinder pressure. For a specific speed (rpm) and load, peak power output occurs when the combustion pressure reaches a maximum at approximately 6 degrees of crank rotation after TDC.

IGNITION ADVANCE/RETARD

Ignition timing, however, is not constant. The timing of the spark must be either advanced (occur earlier) or retarded (occur later) depending upon conditions. While the speed at which the air/fuel mixture ignites is roughly constant, the speed of the pistons moving up and down obviously varies – faster as the engine revs higher, and slower at idle.

- The faster the engine is operating, the earlier the spark has to occur. This is called advancing the spark.
- It may be necessary to retard the ignition to reduce harmful exhaust emissions, or for other driveability issues.
- Retarding the ignition timing can also help reduce engine knock, which is abnormal combustion with multiple flame fronts and high pressure spikes within the combustion chamber.

Retarding or advancing the ignition timing is the role of the distributor in conventional ignition systems. In modern engines, the most appropriate timing is determined by the Engine Control Unit, which uses a number of sensors and inputs, including a knock sensor to determine when to retard the timing.

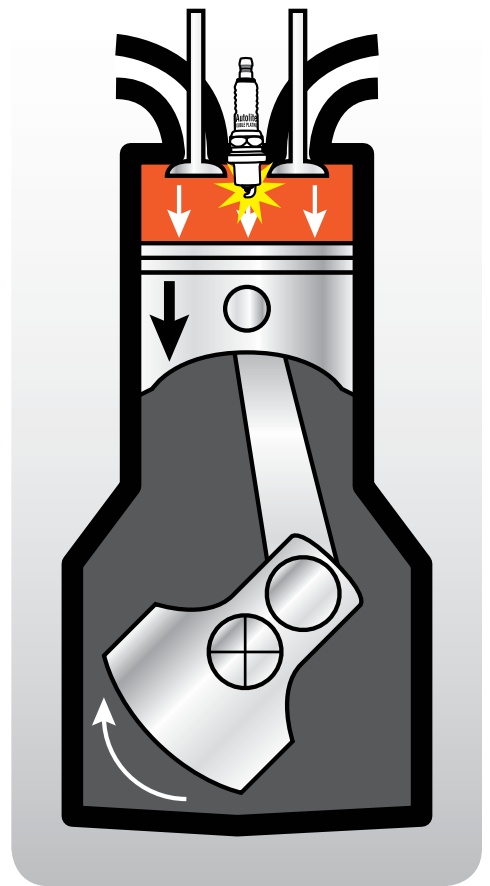

THE ROLE OF THE SPARK PLUG

Spark Plug Performance Requirements

A spark plug has to deal with extraordinarily severe operating conditions:

Severe Temperature Changes

- When starting a cold engine, the spark plug is obviously the same temperature as the ambient air
- During high load operating conditions, the temperature of the burning gases inside the combustion chamber can reach 3,000° C
- When operating at these high temperatures, the incoming air/fuel mixture is dramatically colder. The spark plug must withstand this severe hot/cold cycle repeatedly

Severe Pressures

- During the compression cycle, cylinder pressures can reach 700 psi (50 bar)
- During the combustion cycle, cylinder pressures can reach several thousand psi
- The physical strength of the spark plug must be able to withstand these high pressures

High Voltage

- Within this environment of drastic temperature swings and high pressure, the spark plug must have adequate electrical insulation to prevent high voltage from arcing through the ceramic insulator instead of arcing between the electrodes

Air-Tight Seal

- To ensure proper performance and prevent engine damage, all of the internal components of the spark plug – insulator, terminal post, center electrode and outer shell – must be completely sealed

Radio Interference

- A quality spark plug must be designed with an internal resistor to prevent radio frequency interference

Consistent Performance

- A spark plug must be able to avoid misfires and minimize fouling even under severe operating conditions, including cold-weather starts, hot-weather “soak,” and wide ranges of humidity, barometric pressure and altitude

Longevity

- A spark plug must fire thousands of times per minute for thousands of miles before it needs to be replaced
- Premium quality spark plugs are designed to minimize electrode wear under these extreme operating conditions

THE ROLE OF THE SPARK PLUG

The sole purpose of the ignition system is to serve the spark plugs. The electrical current generated by the coil must be strong enough to arc across the gap at the tip of the spark plug, starting the combustion process.

Proper Spark Plug Gap

The spark plug gap must be set properly before the plug is installed.

- If the gap is too wide, the electrical voltage may not be high enough to arc across, which would result in a misfire
- If the gap is too narrow, the spark may not ignite a “lean” air/fuel mixture, which would also result in a misfire
- Put another way, a spark plug’s voltage requirement is directly proportional to the size of the gap

Do not assume that the spark plug gap was preset at the factory when the spark plugs were made. While Autolite engineers pre-gap spark plugs for the most popular applications, the same spark plug may be designed for two different engines, and these may specify different gaps.

Before you install new spark plugs, adjust the gap using a spark plug gap tool or gap gauge – there are several different designs available.

- If you need to widen the gap, use the spark plug gap tool to pull back on the ground strap (also called the side electrode)
- If you need to close up the gap, gently tap the ground-strap electrode on a hard surface
- **Important:** Do not touch the center electrode or the insulator during this procedure, since these can be damaged

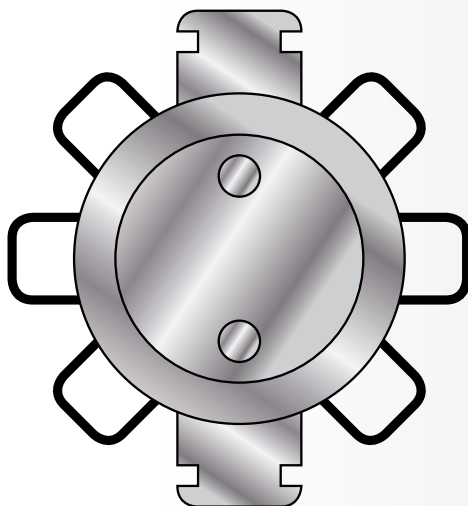

THE ROLE OF THE SPARK PLUG

Insulation

Electrical insulation is very important in any ignition system. The high voltage generated by the coil must flow directly to the spark plug's gap without being diverted or grounded somewhere in between. That's why spark plugs have substantial ceramic insulators surrounding their core. It's also why quality spark plug wires are essential.

- Always check the spark plug wires when installing new spark plugs
- If any of the wires is cracked or shows signs of obvious deterioration, replace the entire set of spark plug wires, including the high-voltage coil lead

Quenching Effects

Remember that combustion starts as a tiny flame kernel in the spark plug. While the flame kernel is trying to generate a strong and consistent flame front, cycle after cycle, the spark plug electrodes have a "quenching" effect, absorbing some of the heat generated and thus trying to extinguish the flame after it has begun.

As you might imagine, if this quenching effect is too strong, combustion will not be complete and the engine will not generate optimal power.

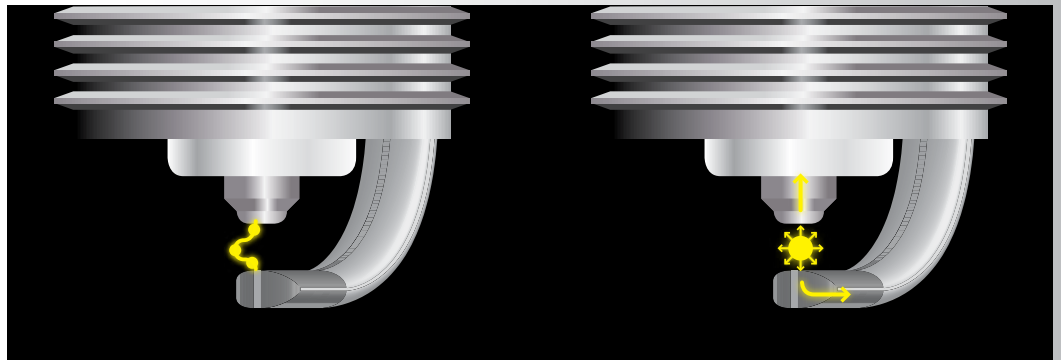

SPARK PLUG HEAT RANGES

The ceramic insulation surrounding the spark plug's core ensures that the strong electrical current from the coil travels directly to the spark plug's electrodes. The tip of this ceramic insulator also has to withstand the very high temperatures and pressures inside the combustion chamber.

While ceramic is a very good electrical insulator, it retains heat. Spark plug engineers take advantage of this fact, since the heat retained by the tip of the ceramic housing that's exposed in the combustion chamber actually helps burn off deposits so they won't accumulate on the electrodes.

Different engine designs require different amounts of this heat transfer and burn off. These differences are called the heat ranges of the spark plug.

- The exact same spark plug design may be available in several different heat ranges
- Vehicle and engine manufacturers specify the proper heat range for each application
- The proper heat range spark plug will allow the tip of the ceramic insulator to get hot enough to burn off deposits, but not so hot that it will pre-ignite the air/fuel mixture before the spark plug fires

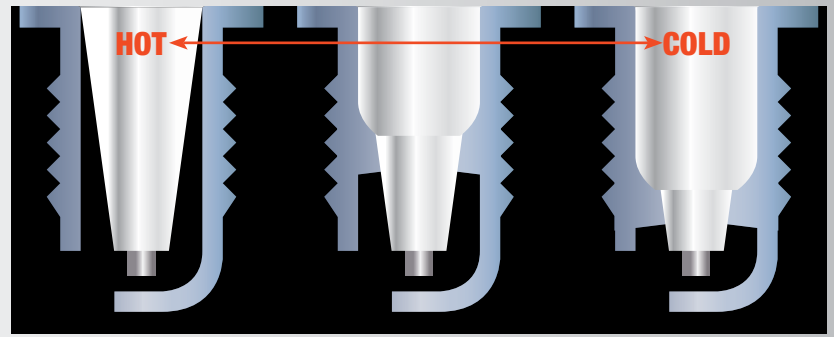

Pre-ignition should not be confused with engine knock. Pre-ignition is when something in the combustion chamber — often the spark plug — gets so hot that it ignites the air/fuel mixture before the spark plug fires.

- A **“hot” spark plug** has a long insulator with more surface area exposed in the combustion chamber. This spark plug will stay hotter, helping to burn off residue and deposits
- A **“cold” spark plug** has very little exposure of its ceramic insulator to the combustion chamber. This spark plug will run cooler
- Do not confuse this use of **“hot”** and **“cold”** with a **“hot”** (high-performance) engine

Some cars with high-performance engines – higher compression ratios, or supercharging or turbocharging – generate more heat, so they require a colder spark plug. Other types of vehicles require hotter spark plugs. It's important to use the heat range that's recommended by the vehicle manufacturer. The manufacturer has selected a heat range that keeps the insulator tip hot enough to keep it clean of conductive deposits (carbon), but not so hot that the spark plug causes pre-ignition.

Indications Of Improper Heat Range

If the spark plug used in an engine is too hot for its application, it could result in:

- Excessive rate of electrode erosion, excessive gap growth
- Center and ground electrode damage (burned or melted)
- Damaged engine valves
- Damaged pistons due to excessive pre-ignition

If the spark plug is too cold for its application, it could lead to:

- Misfires due to fouling

CHANGES IN VOLTAGE REQUIREMENTS

The voltage that is needed to create the proper flame kernel at the spark plug's electrodes varies based on a number of factors, some related to the spark plug itself and others to engine operating conditions.

Spark Plug Gap

Voltage needs to rise in proportion to the size of the spark plug gap. It's important to note that the spark plug gap widens as the electrodes wear. As a result, old, worn spark plugs will require more voltage to avoid a misfire.

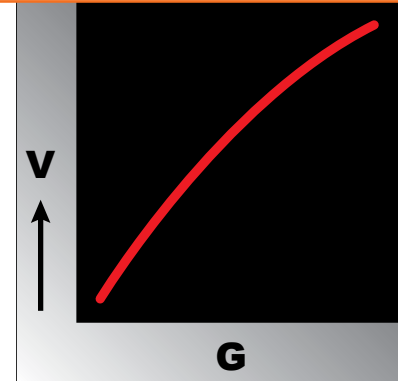

G: Spark plug gap
V: Required voltage

Electrode Condition

If you look closely at the ground strap electrode of a spark plug, you may notice precisely honed edges and even a raised platinum tip. These are scientifically designed to enhance ignition. Over time, these finely chiseled edges will wear and become more rounded, requiring more voltage in order to generate a proper flame kernel.

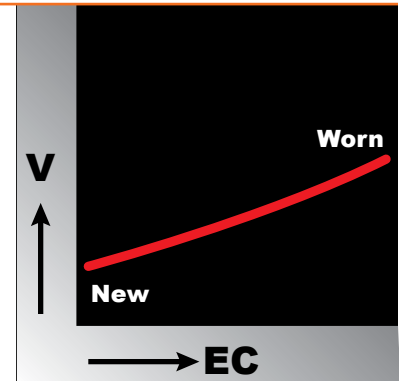

EC: Electrode condition
V: Required voltage

CHANGES IN VOLTAGE REQUIREMENTS

Cylinder Pressure

Voltage requirements rise in relation to cylinder pressures, which are highest at low speed and high load situations, such as accelerating from a standstill. Under these circumstances, and under high RPM operation, higher voltage is required to avoid misfires.

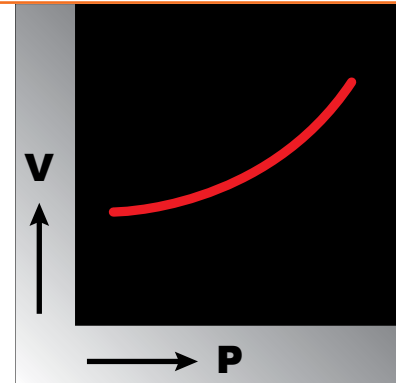

P: Cylinder pressure
V: Required voltage

Air/Fuel Ratio

The leaner the air/fuel ratio – the less gasoline per volume of air – the higher the voltage requirements. As automakers try to make engines more fuel efficient with fewer exhaust emissions, lean air/fuel ratios are common. But if the air/fuel ratio becomes too lean, a misfire could occur.

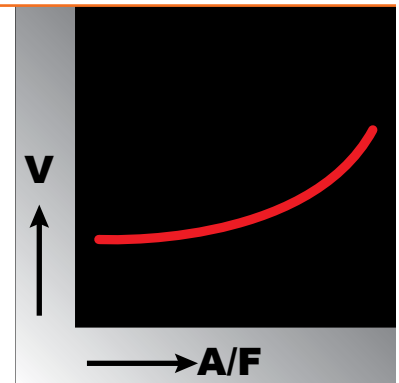

A/F: Air/fuel ratio
V: Required voltage

Air/Fuel Temperature

The lower the overall engine temperature, the higher the required voltage. Misfires can occur more readily at low operating temperatures.

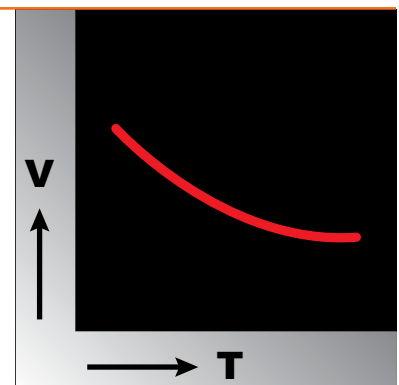

T: Air/fuel temperature
V: Required voltage

CHANGES IN VOLTAGE REQUIREMENTS

Electrode Temperature

As the electrode temperature rises, the required voltage drops. Since electrode temperature rises at higher engine speeds, misfires can occur more readily at low engine speeds.

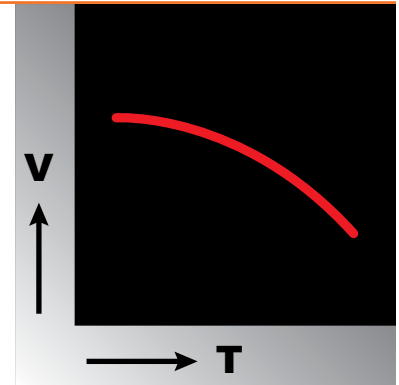

T: Electrode temperature
V: Required voltage

Humidity

As the ambient humidity rises, electrode temperature decreases, requiring higher voltage to generate a proper flame kernel.

Important: If operating conditions continually require higher voltage, the coil, wire set and boots may fail prematurely.

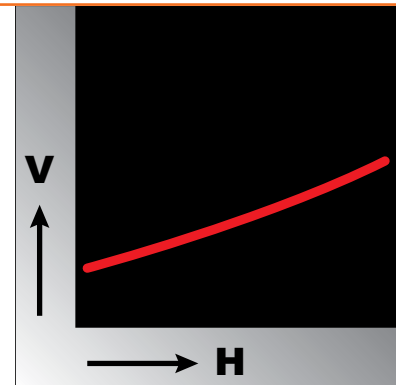

H: Relative humidity
V: Required voltage

ANATOMY OF A SPARK PLUG

It may seem like a relatively simple device, but a modern, high-quality spark plug is a complex mechanism that must be manufactured to tight tolerances. Here's a look inside an Autolite Double Platinum spark plug.

1. Terminal Post

One-piece terminal post adds strength.

2. Multi-Ribbed Insulator

Reduces the danger of "flash-over" – an electrical spark between the metal shell and the terminal, which would cause the engine to misfire. Such an external spark obviously means there is no spark at the electrodes.

3. RFI Resistor

All Autolite® plugs contain radio frequency suppressors to reduce ignition noise that can sometimes be heard on the vehicle's radio.

4. Center Electrode

Full copper core center electrode provides optimal performance in all conditions.

5. Steel Shell

The cold-formed steel shell is manufactured with precision rolled threads for a secure fit, and easy installation and removal. In addition, the spark plug's shell must provide an electrical ground to the cylinder head, and help cool the plug by transferring heat to the head.

6. Bonded Seal

The copper/ceramic seal bonds the insulator, terminal post and center electrode for a leak-proof, gas-tight seal, ensuring full required voltage at the electrode gap.

7. Ground Strap Electrode

Also called the side electrode, it is made of high-nickel chromium alloy and has a platinum tip for superior engine performance, improved fuel economy and easier starts.

8. Center Electrode

The necked-down platinum tip on the center electrode is the perfect complement to the platinum tipped ground-strap electrode, helping to form a consistently ideal flame kernel in the gap.

9. Proprietary Process

Platinum is applied to the electrodes using a proprietary ball welding process. Double Platinum spark plugs exhibit virtually no gap erosion compared to standard plugs.

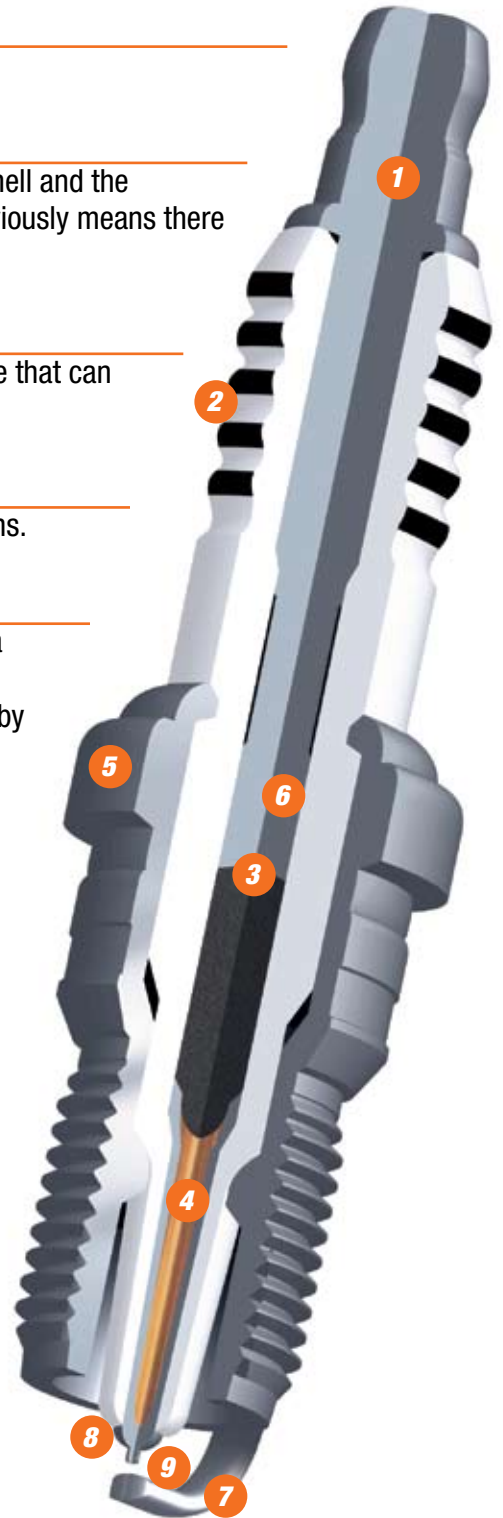

TYPES OF SPARK PLUGS

There are a wide variety of spark plugs available for many different engine configurations and types – everything from small engine spark plugs for lawn mowers, to high-performance plugs for racing applications.

Spark plugs can be categorized in many different ways:

- Copper
- Platinum
- Iridium enhanced

- Compact
- Standard
- Extended Reach

- Standard
- Racing
- Long-Life

Autolite® Spark Plugs

While the Autolite spark plug line-up may vary in different world markets, the North American Autolite line-up includes:

- Autolite® Copper Core
- Autolite® Platinum
- Autolite® Double Platinum
- Autolite® Revolution HT®
- Autolite XP Xtreme Performance®
- Autolite® Racing Hi-Performance®

For small engines and motorcycles, Autolite offers:

- Autolite® Small Engine
- Autolite® Xtreme Start™
- Autolite® Xtreme Sport®



TYPES OF SPARK PLUGS

Autolite® Copper Core

Guaranteed to deliver quick starts, dependable performance and smooth acceleration, Autolite® Copper Core plugs are the industry standard.

- Super heat dissipation and durability
- Improved fuel economy
- Smooth acceleration
- Lower emissions
- 2-year limited warranty

Autolite® Platinum

Manufactured with a center wire platinum firing tip. Benefits include: Reduced gap erosion, fewer misfires, better performance and more durability than the standard plug.

- Longer life
- Quick starts
- Faster acceleration
- Fewer misfires
- Cleaner firing and improved efficiency over the life of the plug compared to worn plug
- 3-year limited warranty

Autolite® Double Platinum

Feature platinum-to-platinum firing. Virtually eliminates gap erosion, reduces misfires and provides 100,000-mile durability. It's a superior performance spark plug providing preferred technology for distributorless ignition engines.

- Superior performance
- Longer life compared to standard plugs
- Improved efficiency over the life of the plug compared to worn plug
- 5-year limited warranty

Autolite® Revolution HT®

Unique, patented design improved for greater durability. High-Strength Steel (HSS) Technology helps prevent separation of shell and ground shield.

- Patented Autolite technology
- Exclusively designed for Ford Motor Company's Triton three-valve engines
- Four heat ranges available: HT1, HT1.5, HT2 and HT0 for modified (boosted or nitrous injection) engines



TYPES OF SPARK PLUGS

Autolite XP Xtreme Performance®

One of the brand's most technologically advanced spark plugs ever. With an iridium enhanced 0.6 mm fine wire design and patented platinum sidewire technology, these spark plugs provide better durability** and a more focused ignition for optimum performance.

- Better overall ignitability*
- Greater overall durability**
- Better overall value

*Compared to 0.8 mm fine wire, multi-electrode design and standard plugs

**Compared to average of other premium brands



Autolite® Racing Hi-Performance

Actual racing spark plug used by many professional car drivers. Anti-corrosive nickel plating and large, cut-back ground electrode for better heat transfer.

Autolite® Small Engine

Engineered to meet or exceed original equipment designs, these spark plugs combine quality and performance for small engine needs. A precision fine wire tip requires less voltage (versus a standard small engine plug), which leads to quick, consistent starts.

Autolite® Xtreme Start™

From lawn mowers to chain saws, this plug provides quicker consistent starts versus the average plug and an anti-fouling design. Features a platinum fine wire tip that helps with easy starting, reduces fouling and ensures longer performance.

Autolite® Xtreme Sport®

Engineered to meet or exceed original equipment designs and withstand the extreme operating temperatures experienced during a powersports engine's combustion. Iridium enhanced 0.6mm fine wire design for improved ignitability, faster fuel combustion and a more focused ignition versus standard plugs.

HOW TO READ AUTOLITE® SPARK PLUG NUMBERS

The Autolite spark plug numbering system is easy to understand, and the alphabetical prefix makes it easy to go from a Copper Core to a Double Platinum spark plug of the same number.

XP

The prefix indicates the type of plug.
– = Copper Core (no alpha designation)
AP = Platinum
APP = Double Platinum
XP = Iridium-Enhanced

542

These main (middle) numbers, which can be two digits or three digits, designate the spark plug family.

If the last digit of this spark plug family designation is even, it is a resistor/suppressor type spark plug. If the last digit is **odd**, it is a non-resistor spark plug.

6

The very last digit in the number indicates the heat range. In this case, **XP 542 5** would be a colder plug. A **XP 542 7** would be a hotter plug.



SELECTING THE RIGHT SPARK PLUG

A common mistake among do-it-yourself mechanics is to use the wrong type of spark plug for their engine. While matching the numbers for the spark plug family is crucial, it is also important to match the type of spark plug to the ignition system. Use this list as a guide, but always follow the vehicle manufacturer's recommendation:

Autolite® Copper Core	Conventional breaker-point ignition system
Autolite® Copper Core or Autolite® Platinum	High-energy (electronic) ignition system
Autolite® Double Platinum or Autolite XP Xtreme Performance®	Distributorless (waste-spark) ignition system
Autolite® Platinum or Autolite XP Xtreme Performance®	Coil on plug (direct) ignition system
Autolite® Small Engine or Autolite® Xtreme Start™ or Autolite® Xtreme Sport®	Capacitor discharge ignition (CDI) system

Failure to match the type of the plug to the ignition system can result in misfires or even component damage. It's also important to use the correct heat range. Unless the engine is modified (i.e., supercharged, turbocharged or nitrous injection), use the heat range specified by the manufacturer.

Finally, make certain to gap the spark plug to the correct specification for optimal performance and efficiency.

INSTALLATION GUIDE

Installation Guide

Replacing spark plugs may seem like a simple job, but proper procedures must be followed to ensure the best results. While you should always use the vehicle manufacturer's service procedures, which may include removal of certain engine components to access the spark plugs, here is a basic a step-by-step guide.

1. Be sure that the engine is cool before beginning.
2. Carefully remove the spark-plug boots. Grasp the boot, twist it about a quarter turn to break the seal, and then lift it straight off. If the boot does not break free easily, use a spark-plug boot puller. As you remove the boots and ignition wires, number them using tape and a marker.
3. Clean the area around the spark plugs using a blast of compressed air, or by blowing through a soda straw. This prevents debris from falling into the combustion chamber when the old spark plugs are removed.
4. Loosen each spark plug using the correct hex-head socket wrench.
5. Remove the spark plugs and line them up in cylinder order. Inspect the spark plugs to identify any engine problems that may need attention. (See the "Troubleshooting" section.)
6. Gap the new spark plugs as recommended by the vehicle manufacturer. Use a rounded feeler gauge or a specific gapping tool to measure the gap between the center electrode and side electrode. The gauge should pass through the gap snugly but easily. If too loose or too tight, adjust the gap as needed.

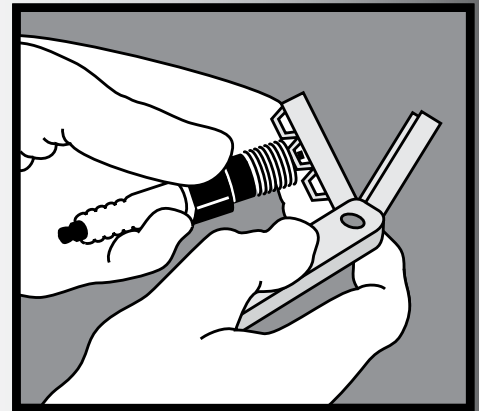
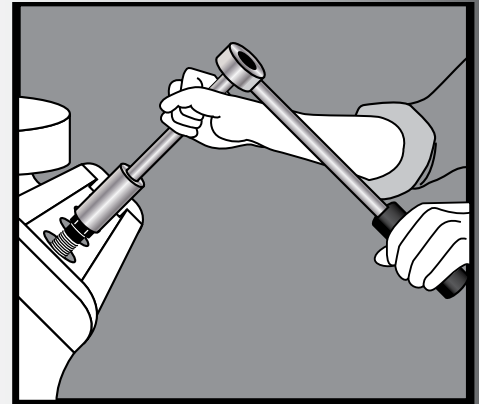

Note #1: Always replace spark plugs as a complete set. This is especially important with computer-controlled ignition systems.

Note #2: It is very important to properly tighten all of the spark plugs. Too little torque can cause the spark plug to leak combustion gases. Over-torquing the spark plug can damage both the plug and the threads in the cylinder head.

Note #3: Do not use any grease or lubricant on the spark plug threads since this may result in over-torquing the spark plugs, and could lead to engine damage.

INSTALLATION GUIDE

7. Screw the new spark plugs in by hand until just finger tight. If it is difficult to reach the spark plug socket, use a length of rubber hose to extend your reach.
8. Tighten the spark plugs using a torque wrench and following the vehicle manufacturer's recommendations. If you do not have a torque wrench, use the tightening chart (below).
9. Before replacing the ignition wires and spark-plug boots, check them for any cracks or brittleness, or obvious signs of corrosion or wear. Replace the entire set if you detect any of the above defects.
10. Place a small amount of dielectric grease inside the spark-plug boot where it connects to the spark-plug barrel (ribs). This will help ensure a tight, moisture resistant seal and help resist flashover.
11. Replace the spark-plug wires in the correct order, following your marks. Make sure that the ignition wires are routed correctly and will not come into contact with hot engine components.
12. Start the engine. If the engine misfires or idles badly, shut it off and double-check that the ignition wires are not crossed or connected poorly. Check the firing order and all the connections carefully.

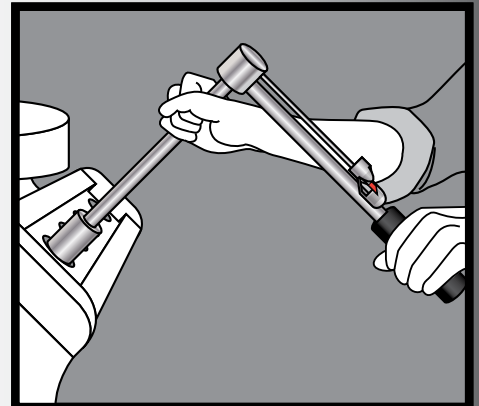
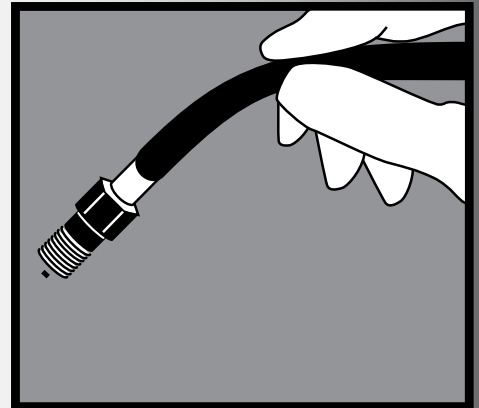

INSTALLATION GUIDE

Installing Spark Plugs Without A Torque Wrench

It is always best to use a torque wrench to install spark plugs. If a torque wrench is not available, however, you may use this chart as a guide. (Note: These suggestions are for spark plugs with new gaskets.)

Spark Plug Thread/Seat	Tightening Procedure
14mm and 18mm tapered seat	Tighten 1/16 turn after finger tight
14mm and 18mm gasket seat	Tighten 1/2 turn past finger tight
12mm gasket seat	Tighten 3/8 turns past finger tight
10mm gasket seat	Tighten 1/4 turn past finger tight

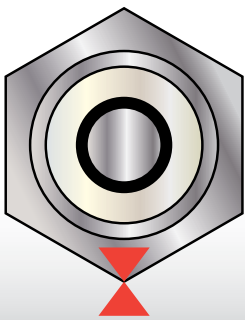

**FINGER
TIGHT**

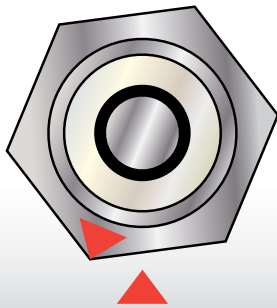

**1/16
TURN**

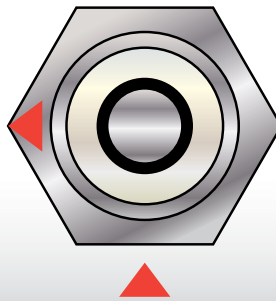

**1/4
TURN**

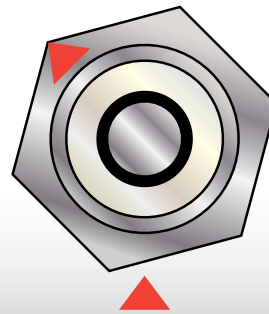

**3/8
TURN**

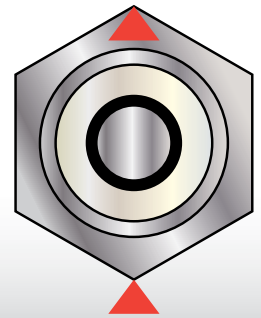

**1/2
TURN**

SERVICE LIFE & MISFIRING

Service Life

Spark plugs are wear items. Even though some of the most premium spark plugs can last over 100,000 miles (160,000 km), eventually all spark plugs wear out and must be replaced to ensure consistent engine performance.

The tip of the center electrode and the ground-strap electrode probably face the most severe conditions, so wear will be most apparent at these points. The extent of electrode wear will vary based on:

- Engine type and operating conditions
- Materials used – iridium and platinum are designed to have longer service lives than other metal alloys

Misfiring

Owners should always follow the manufacturer's suggested service interval unless there are driveability problems due to misfiring. Obviously the ideal service interval for a spark plug is to replace it before it starts to misfire. Some of the possible causes of misfiring are listed below.

SPARK FAILURE: The electrical current is not strong enough to arc across the electrodes of the spark plug.

Possible Causes:

- Ignition coil voltage is too low due to battery condition
- Ignition coil voltage is too low due to ignition coil or igniter condition
- Voltage leak between the coil and the spark plugs
- Dirty or fouled spark plug

SPARK FAILURE: The required voltage is too high to ignite a flame kernel.

Possible Causes:

- Spark plug electrode wear
- Spark plug gap is too wide
- Defective connection between the high-voltage spark plug wires and the spark plug terminal

FAILURE TO IGNITE: The spark plug fires normally, but the air/fuel mixture does not ignite.

Possible Causes:

- The spark plug gap is too narrow
- The air/fuel ratio is too lean or too rich

SERVICE LIFE & MISFIRING

Catalytic-Converter Damaging Misfires

On modern engines with computer-controlled ignition systems and onboard diagnostics, certain types of misfires will trip the Malfunction Indicator Light (MIL – also called a check engine light). The driver may experience a rough idle, sluggish performance and/or poor fuel economy as a result of a misfire.

If the MIL flashes, this generally indicates a catalyst-damaging misfire, which must be investigated and repaired immediately.

Possible Causes:

- Fouled spark plugs
- Worn engine components
- Use of the wrong type of spark plug for the vehicle, such as Copper Core or Single Platinum plug used with a Distributorless Ignition System engine
- Faulty ignition wires or Coil On Plug boots
- A faulty ignition coil

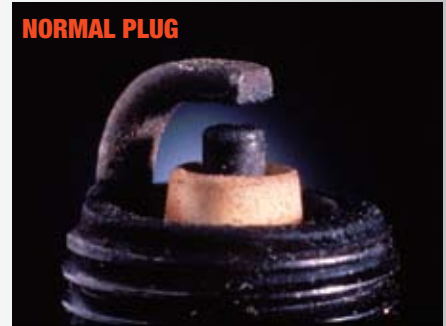

Spark Plug Fouling

Many different factors can contribute to spark plug fouling:

- The air/fuel ratio is too rich due to incorrect carburetor adjustment or a poorly performing fuel injection system
- Worn piston rings or valve seals may allow too much oil to enter the combustion chamber
- The ignition system may not be performing properly
- Prolonged idling or continuous low-speed driving may keep the spark plugs from reaching optimum operating temperatures
- Use of a spark plug with a heat range that is too cold
- A dirty air cleaner, which can create a too-rich condition



TROUBLESHOOTING

Examining the spark plugs that are removed from an engine can help you determine if the engine has problems that need to be corrected. Here's what to look for.

1. Normal – Grayish-tan to white in color. No unusual signs of deterioration or coatings.



2. Red coating – Pinkish red coating on the ceramic insulator tip, center electrode and ground electrode. Sometimes spark plugs will have a slightly red coating, which is the normal result of additives used in some unleaded gasoline.



3. Worn out – The center and ground electrodes are eroded, have rounded edges and are excessively worn away. Difficulty starting the engine and misfiring during acceleration may occur. This indicates a spark plug that has been used beyond its intended service life.



4. Fuel fouled – Firing tip may be damp with gasoline, and usually the odor of gasoline is present on the spark plug. The insulator is often tinted the color of charcoal. This indicates that gasoline is not being burned properly in this cylinder. Check for faulty or sticking choke, overly rich fuel mixture, ignition problems, leaking fuel injectors or a spark-plug heat range that is too cold.



TROUBLESHOOTING

5. Oil fouled – Center electrode, ground electrode and/or ceramic insulator tip are coated with a black, oily substance. This is caused by the presence of oil in the combustion chamber. Check for worn rings, valve guides and/or valve seals. In two-stroke engines, this could be the result of high oil content in the fuel mixture.



6. Carbon fouled – Dried, soft black, sooty coating. There are a number of possible causes for this condition: Spark-plug heat range is too cold; extensive low-speed/short-distance driving; weak ignition system; rich fuel mixture; clogged fuel injectors; vacuum leaks; carbon canister/purge valve problems. Carbureted engines with carbon-fouled plugs may be improperly adjusted or have an improperly adjusted choke.



7. Lead fouled – Ceramic insulator tip is coated with a brownish-yellow glazed coating. This condition occurs from the use of leaded fuel or fuel additives containing lead.



8. Glazing – Ceramic insulator tip appears to have a melted, glazed coating. Here the spark plug shows that the engine has been operating too hot at high speeds. These plugs should be replaced with a colder heat range.



TROUBLESHOOTING

9. Detonation damaged – The insulator is usually cracked, chipped or broken, and the ground electrode may also exhibit damage. This spark plug exhibits signs of detonation, which can be caused by the use of low-octane gasoline or an overly advanced ignition timing. Check for a faulty EGR system, knock sensor and correct spark-plug heat range.



10. Sustained pre-ignition damage – Melted center and ground electrodes and damaged ceramic insulator tip. Sustained pre-ignition has noticeably damaged this plug. Check to be sure that the right specification of spark plug was used (heat range too hot or simply the wrong plug for this application). Also check for cross-firing of the ignition cables, over-advanced timing, lean fuel mixture, defective EGR valve, carbon deposits/hot spots inside the combustion chamber due to poor heat dissipation, improperly torqued spark plugs when installed, or head gasket intrusion into the combustion chamber.



11. Physical damage – Center electrode and ground electrode are bent out of position. Ceramic tip is broken and missing. This is a serious condition caused by a possible foreign object inside the cylinder. Also check for the improper spark plug thread due to the use of the wrong spark plug for this application.



12. Ash deposits – Center electrode, ground electrode and/or ceramic insulator tip are coated with tan-colored deposits. This condition may be caused by the use of leaded gasoline, certain gasoline and/or oil additives. Also check for worn piston rings and/or valve guides. Misfiring may occur due to these deposits.



TROUBLESHOOTING

13. Corona stain – The insulator has a brownish-yellowish stain, usually just above the shell, but there are no apparent cracks or spark plug damage. This condition is caused by electromagnetic fields in the air around the engine. While it may look like a spark plug gas leak, it is not. There is no impact on spark plug performance.



14. Insulator breakage – Cracked or visibly broken ceramic insulator, usually caused by over-torquing the plug during installation or removal, or by dropping it on a very hard surface prior to installation. Will result in rough idle and misfires under load.



15. Flashover – Dark vertical lines and deterioration of the spark plug in the ribbed area of the insulator from a short between the metal spark plug shell and the terminal nut. Likely misfires. Can be caused by a variety of factors, including old/cracked spark plug boots, dirt or residue on the insulator, incorrect spark plug gap (too large) or even highly ionized air from an electrical storm.

FREQUENTLY ASKED QUESTIONS

Q: How often should spark plugs be replaced?

A: Autolite engineers recommend following the spark plug service interval established by the vehicle manufacturer. This should be listed in the owner's manual or shop manual. Autolite spark plugs should be replaced at least as often as the vehicle manufacturer recommends. For more information about common service intervals in your area or region, you may also want to ask a local vehicle dealer or a reputable automotive service facility.

Q: Why do spark plugs need to be replaced?

A: One of the most economical ways to maintain an efficient engine and avoid wasting fuel is to change spark plugs at regular intervals. As spark plug electrodes wear, the voltage required to arc across the gap increases. Under hard acceleration, high speeds or heavy loads, misfires can occur, which will waste fuel.

Q: Why do spark plugs need to be tightened to a specific torque setting during installation?

A: It is very important to properly tighten spark plugs during installation. Too little torque can cause the spark plug to leak combustion gases. Over-torquing can damage both the spark plug and the threads in the engine head. Both can cause extensive engine damages.

Q: Do Autolite® spark plugs come pre-gapped from the factory?

A: Autolite spark plugs are pre-gapped for the most popular applications. Because of the different gap sizes specified by different manufacturers, however, this may not be the correct gap for your application. Gapping has always been the job of the installer. The gap can easily be adjusted as required.

Q: Should iridium enhanced spark plugs be gapped before installation?

A: No. This is an exception to the above. Most technicians will not know how to properly gap an iridium spark plug, and the fine-wire center electrodes on these plugs can easily snap if mishandled. There is no warranty for snapped center electrodes.

Q: What is a fouled spark plug?

A: Spark plugs can become "fouled" by excessive fuel, oil or combustion deposits in the combustion chamber. Essentially what this means is that the spark plug insulator tip has become coated or covered by deposits. When this happens, the spark plug either will not fire reliably, or the electrical current may flow from the center wire over the insulator's deposits, to ground at the steel shell.

Q: What is detonation?

A: Detonation is the result of two flame fronts colliding in the combustion chamber. What that means is that the air-fuel mixture has been ignited almost simultaneously in two locations within the combustion chamber. One flame front was probably ignited by the spark plug, while the second front was ignited spontaneously. The most common causes of detonation are octane that is too low for the application or overly advanced ignition timing. The result produces the characteristic "knock" or "ping" sound. If left unchecked, detonation can cause serious engine damage, such as broken or bent valves and spark plug tips.

FREQUENTLY ASKED QUESTIONS

Q: What is pre-ignition?

A: Pre-ignition is when combustion begins before the spark plug fires. The ignition point can be a hot spot, such as glowing deposits, overheated spark plug electrodes or an extremely hot exhaust valve. Causes also include a spark plug whose heat range is too hot for the application, a lean air/fuel mixture, a defective EGR valve or over-advanced timing. Sustained pre-ignition will likely melt spark plug electrodes, and it can burn holes in valves and pistons.

Q: How can I determine what kind of engine is in a specific vehicle?

A: Most cars have an emissions decal under the hood that will indicate the engine size. You can also match the VIN code number with the Autolite application. For most cars, use the eighth digit in the VIN number.

Q: What are the benefits of using a 0.6mm fine wire iridium enhanced spark plug in a motorcycle that originally had a copper core plug?

A: The 0.6mm fine wire design used by the Autolite Xtreme Sport spark plug is engineered to offer:

- Improved ignitability and durability over a standard plug
- Up to 26 percent quicker starts than leading standard plugs
- More focused ignition to prevent fouling than the leading standard plugs
- More horsepower than standard plugs
- A larger flame kernel for more complete burn, faster starts, and better performance and fuel efficiency
- Less firing voltage for more coil dwell time
- Better fuel efficiency over the life of the plug compared to worn plug

Q: Can Autolite® Xtreme Sport® spark plugs be used in a two-stroke engine?

A: Yes. It will deliver up to 26 percent quicker starts and better ignition system performance than standard plugs. The benefits of the fine wire design in Autolite® Xtreme Sport® also include a more focused ignition to prevent fouling, which is a common issue with two-stroke engines.

Q: How do I cross-reference a spark plug from another brand?

A: On the Autolite website (www.autolite.com), click on Autolite Parts Catalog, and then type in the spark plug number in “Competitor Cross Reference.” Do not include the manufacturer’s name. You will be supplied with the equivalent part number, or if the part number you selected is shared with more than one manufacturer, you will be asked what brand you are crossing from.

Q: Can I use a standard copper core spark plug if the vehicle manufacturer recommends a platinum or iridium enhanced plug?

A: No! Using a copper core plug in a vehicle designed for platinum or iridium enhanced plugs can result in loss of performance or even severe engine damage.

Q: Can old spark plugs be cleaned and reused?

A: Yes, but in most cases it’s not worth it. You will not get the same performance from a cleaned plug as a new plug. A used plug will already have wear, and cleaning may contribute to that wear. What’s more, insufficient cleaning of the spark plug may lead to spark plug failure in a very short period of time.

Q: How do I become an Autolite distributor?

A: Please direct inquiries to Information@autolite.com.

AUTOLITE SPONSORED RACING

The Fastest & Most Extreme Form Of R&D

Since 1967, UCI/Framgroup brands – Prestone®, FRAM® and Autolite® – have actively participated in the world of racing. As avid sponsors in National Hot Rod Association (NHRA), AMA Superbike Pro road racing and Snowmobile endurance racing, Autolite has relationships with a number of drivers who constantly push the brands' products under the most extreme conditions.

Autolite racing experts are constantly trackside, helping crews fine-tune their machines and providing them with a variety of high-performance products that meet today's strict racing standards.

From hardcore enthusiasts to backyard mechanics, from the guys at the counter to the guys at the garage, people in the know trust the brands that not only bring excitement to the track, but use that passion and know-how to produce high-quality, long-lasting replacement and performance parts for the real world of everyday driving.

Autolite proves that great products can result from the real-world test-lab of racing. From drag strips and dirt tracks to driveways and highways, Autolite is dedicated to providing technology that helps vehicles, both on and off the field of racing.

NHRA Top Fuel

After driving to another top-ten finish in points last season, Cory "Mac" McClenathan continues his partnership with FRAM in 2010. McClenathan has seventeen top-ten finishes in the NHRA Full Throttle Top Fuel points standings, and ranks sixth all-time on the Top Fuel win list. It takes a great spark plug to fire up this 8,000-horsepower engine, and Autolite can make it happen at over 300 mph!



AMA Pro Series

Autolite-sponsored rider Mike Morgan began his racing career at age 11, initially racing motocross on 80cc motorcycles before moving up to 125cc bikes. At age 17, he transitioned from dirt bikes to road bikes and has never looked back. Mike placed on the podium with a 2nd-place finish in his first year. He continued to place on the podium the following year and won his first race as an amateur.

In 2003, Mike turned expert, and by mid-year he had accumulated enough points to acquire an AMA Professional Racing License. Mid Ohio Sports Car Course was Mike's first AMA Pro race. He finished 21st against Yamaha, Suzuki, Kawasaki and Honda factory teams. In 2006, Mike focused on the AMA Professional Series exclusively, attending 6 out of 11 rounds held across the U.S. To date, the top finish in AMA Pro races for Mike has been 18th, competing against, and sometimes beating, much larger teams. Learn more at www.mikemorganracing.com



AUTOLITE SPONSORED RACING

M.I.R.A. Pro Enduro Snowmobile Racing

Autolite-sponsored Isaac Wolfgang is making waves in the snowmobile racing world. After winning rookie of the year in 2002, he has quickly become the rider to beat on the oval track circuit, winning the 500cc and 600cc Championships in 2009. Riding for Skid Row Racing, he finished 7th in the grueling I-500 race in 2009, the oldest and toughest snowmobile race in the world. This race is a true test of men and machines, and Autolite spark plugs powered him all the way. Learn more at www.wolfgangmotorsports.com



Product Development Rider

Jerry Reeves, Autolite spark plug Engineering Supervisor, has the dual role of using his Pro/Am road racing bike for both Autolite spark plug and FRAM oil filter development. He loves to ride, and we continually use his bike to prove our products under extreme racing conditions.

